

Enable 3D View

Enable 3D View

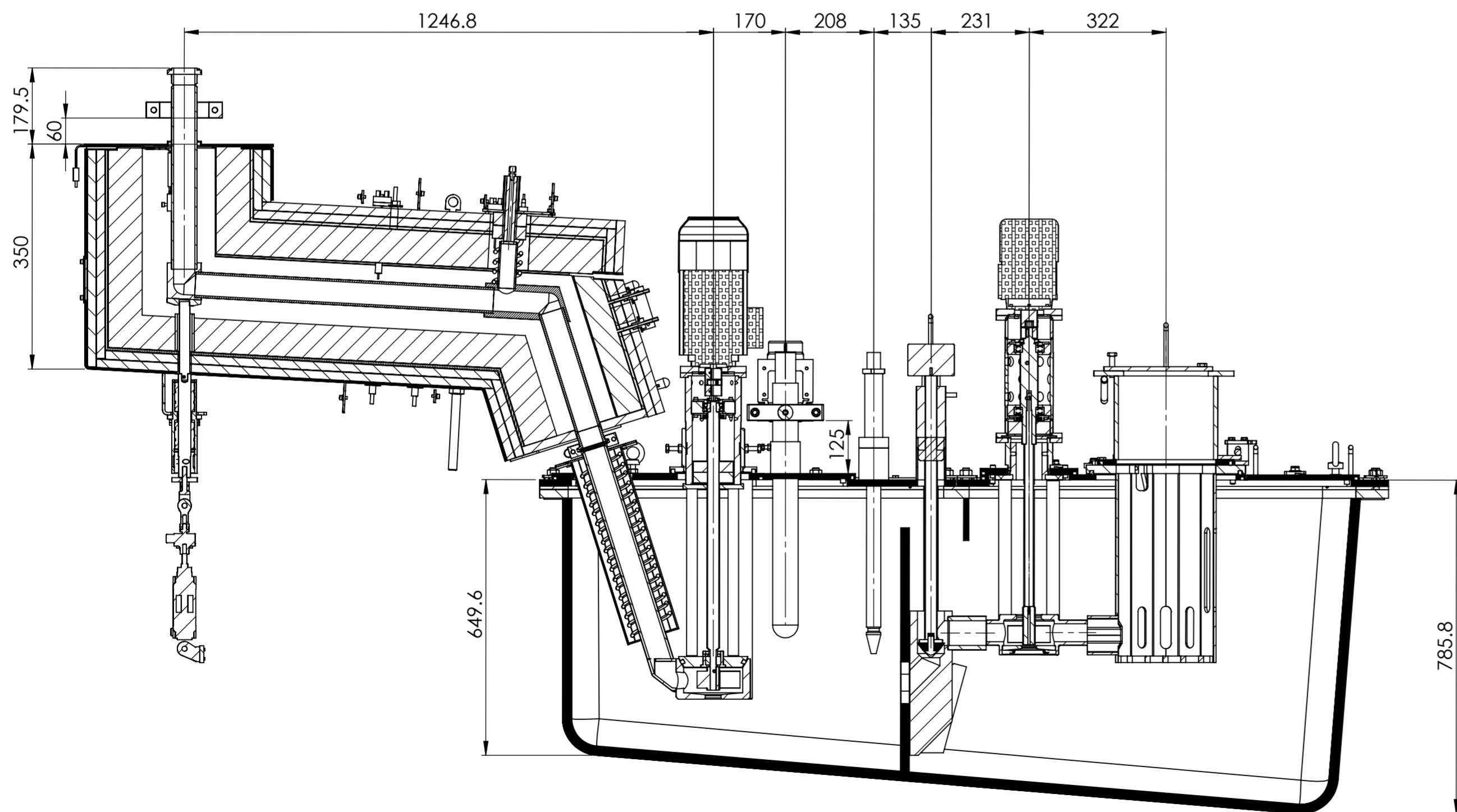

SECTION A-A

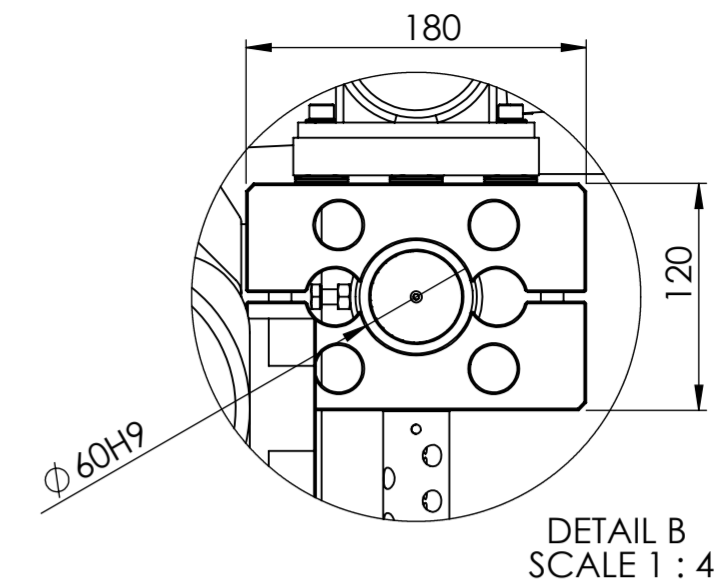
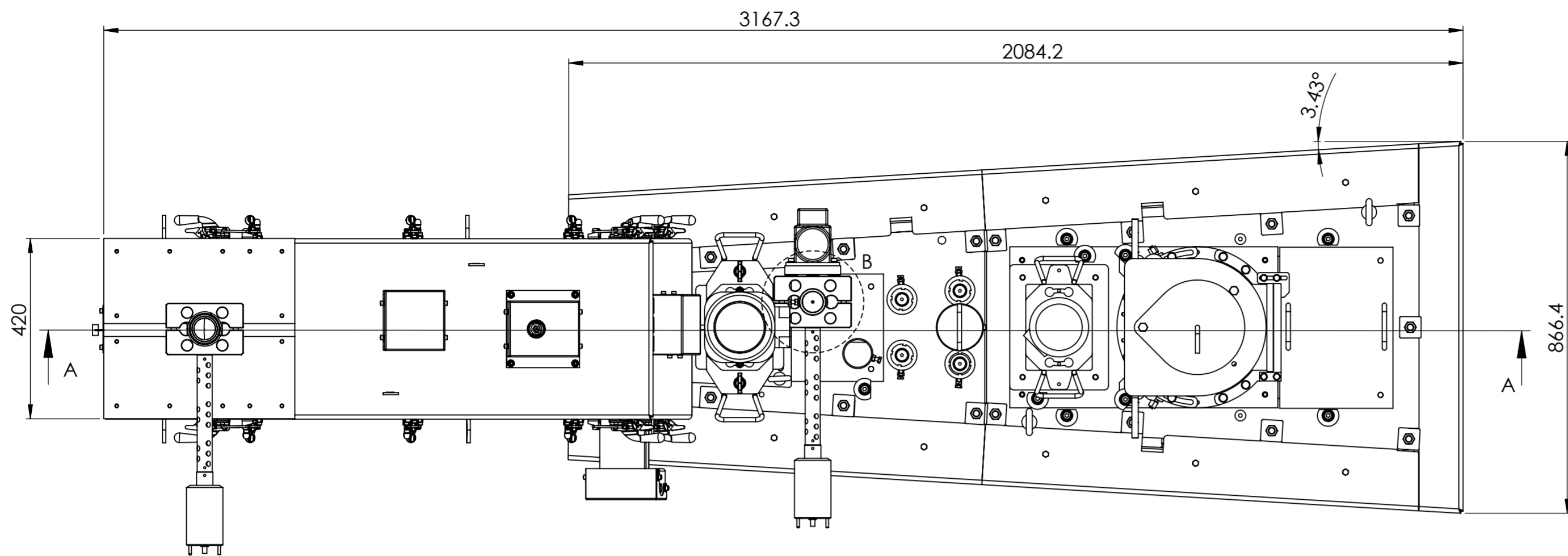
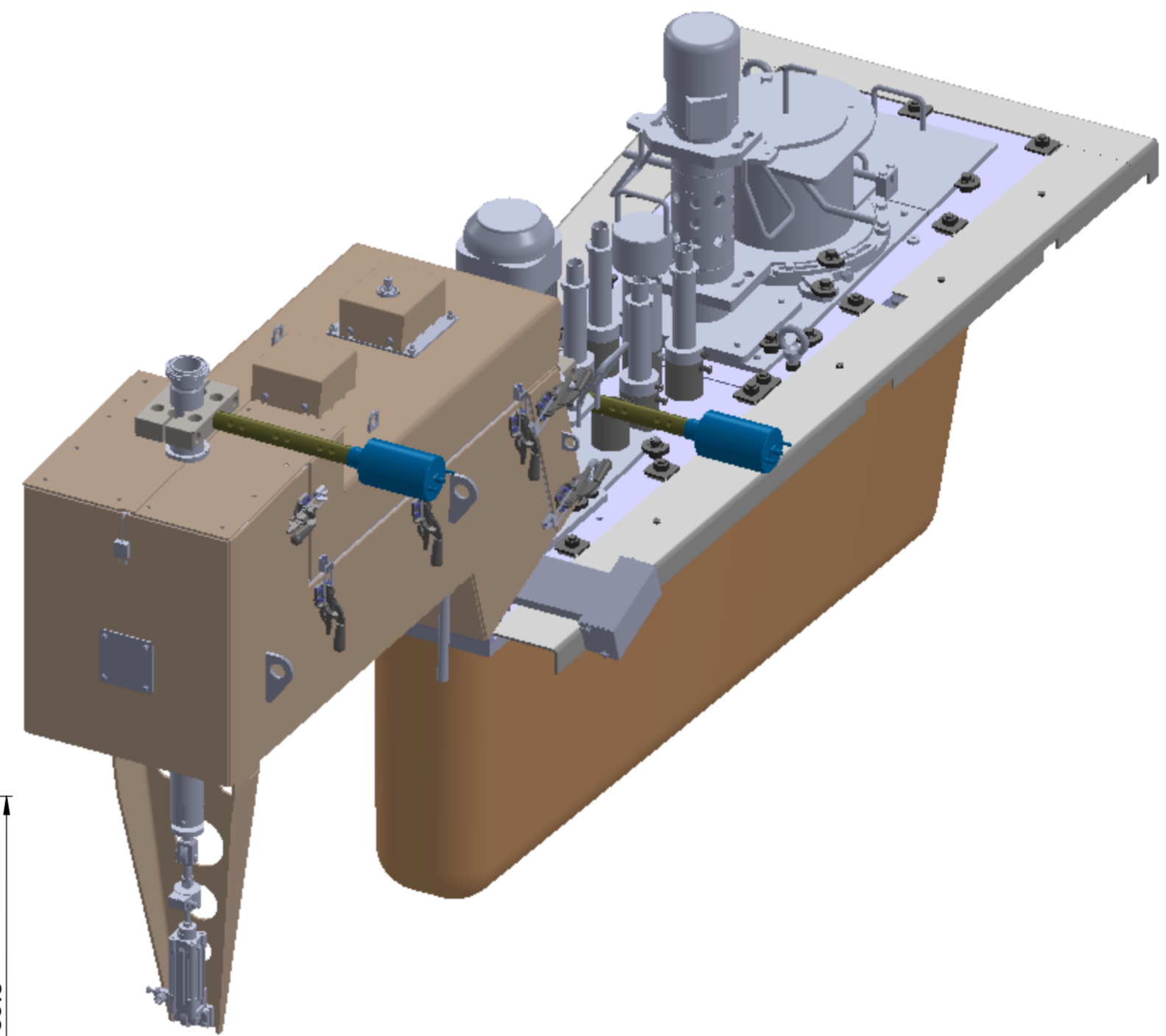

PROJECT DIRECTOR M.Prokic	DATE DATE MODIFY	DEBUR AND BREAK SHARP EDGES	DO NOT SCALE DRAWING	REVISION		
drew H. Puga			MPI-ULTRASONICS MARAI 36 2400 Le Locle Switzerland e-mail : mpi@mpi-ultrasonics.com phone +41 (0) 32 9314045			
MATERIAL:						
General tolerance SN 258440						
dimension nomiale (mm)	>3 ...6	>6 ...30	>30 ...120	>120 ...400	>400 ...1000	>1000 ...2000
Ecart (mm)	0.05	0.1	0.15	0.2	0.3	0.5
			SCALE: 1:10	SHEET 1 OF 1	A2	

Furnace_Magnesium